

## SKETCH-UP Workshop 3

### 1. PRE-BUILT MODELS IN SKETCHUP

There are many available pre-built models, ready and without the need to invent others. The 3D program offers architectural objects, human characters, landscape and construction elements, playgrounds and transport vehicles. In the component library you can find objects of all kinds to play with and practice [3D Warehouse](https://3dwarehouse.sketchup.com) ([sketchup.com](https://sketchup.com))

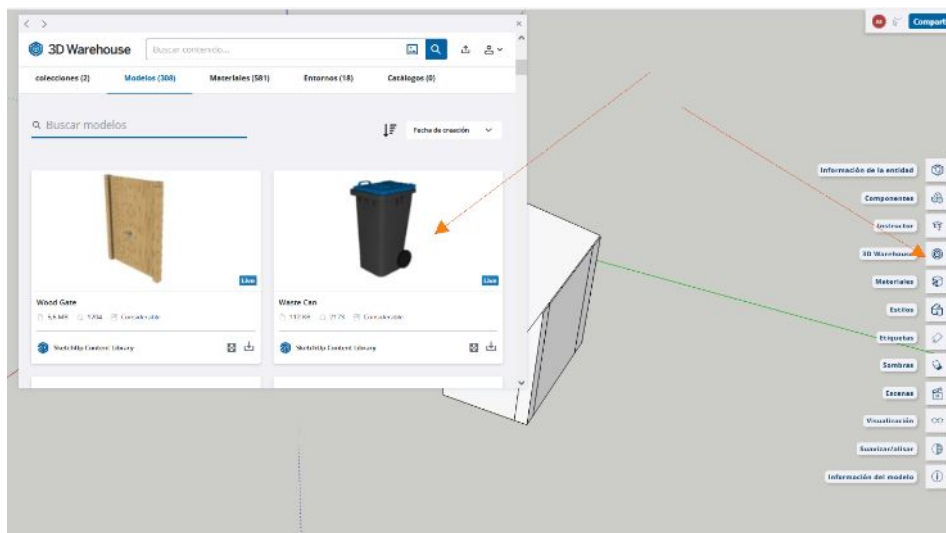

### 2. EQUIDISTANCE TOOL

It makes a figure which is equidistant of another one for example one circle

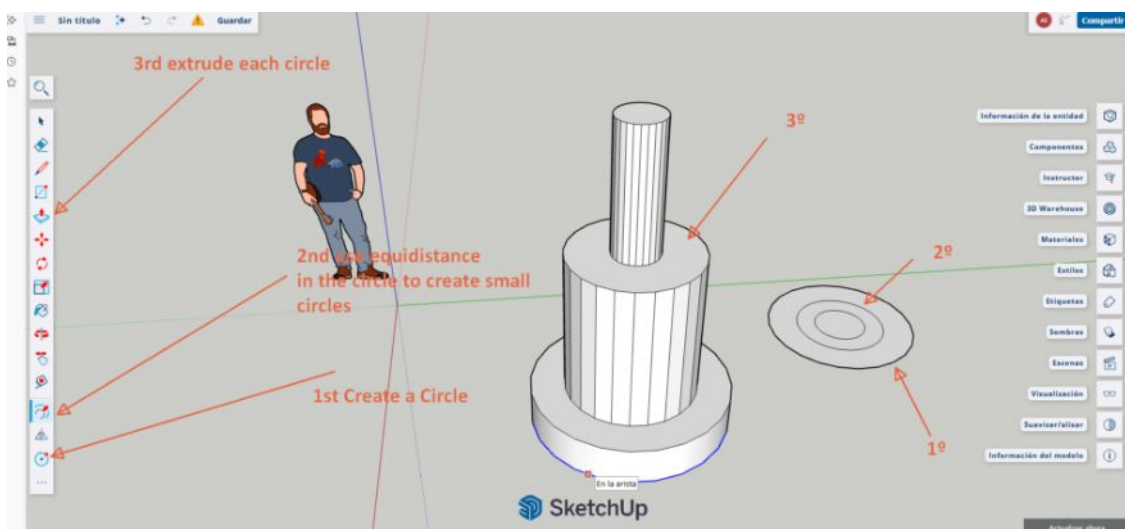

### 3. FOLLOW ME TOOL

It follows a line to create a 3d figure

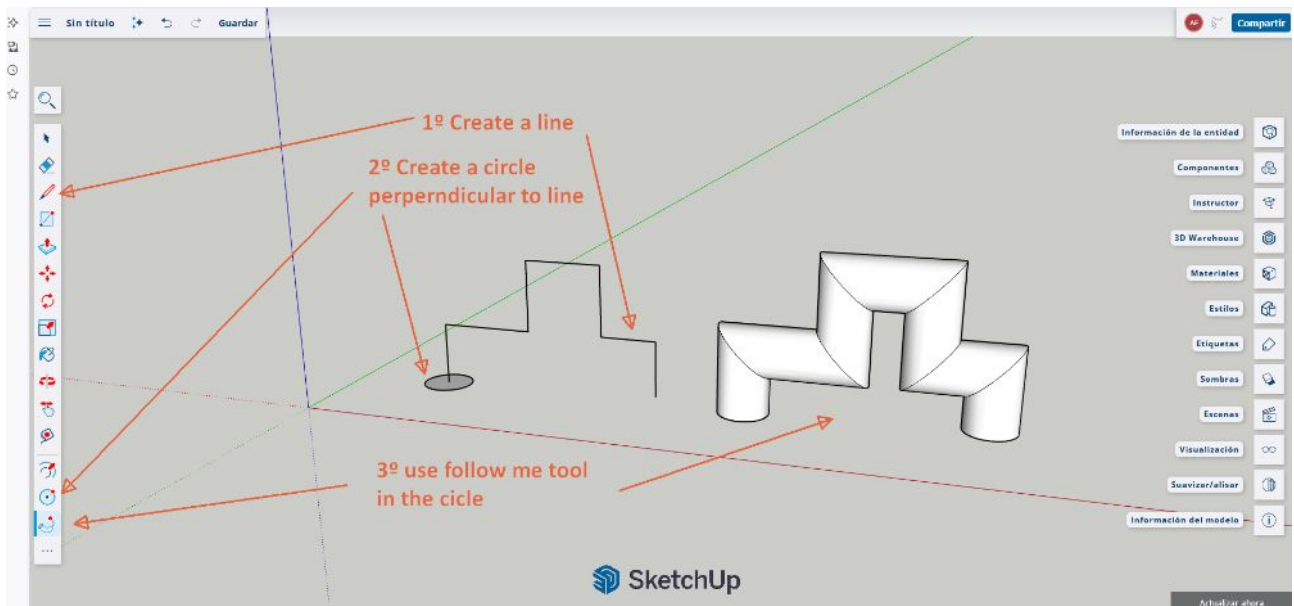

### 4. TASK 1

Create a room and insert several furnitures from the warehouse in it.

### 5. TASK 2

Try create this figures with Equidistance tool

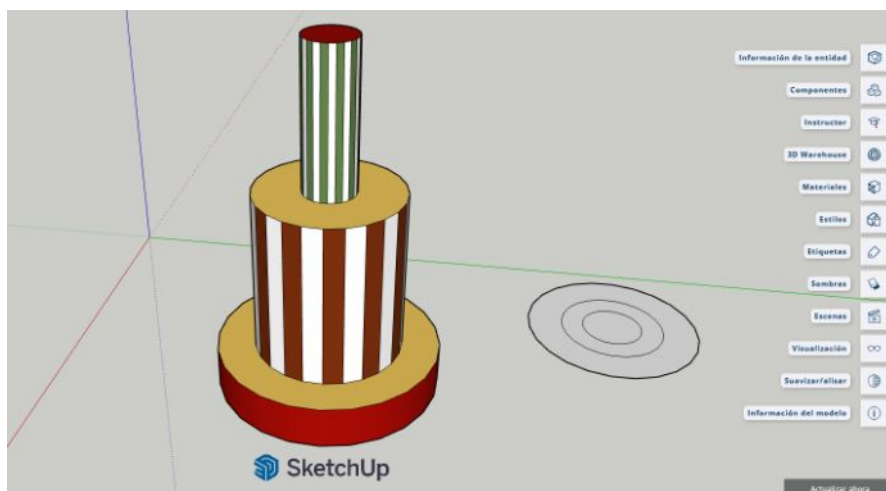

## 6. TASK 3 FOLLOW ME TOOL

Try create this figures with follow me tool

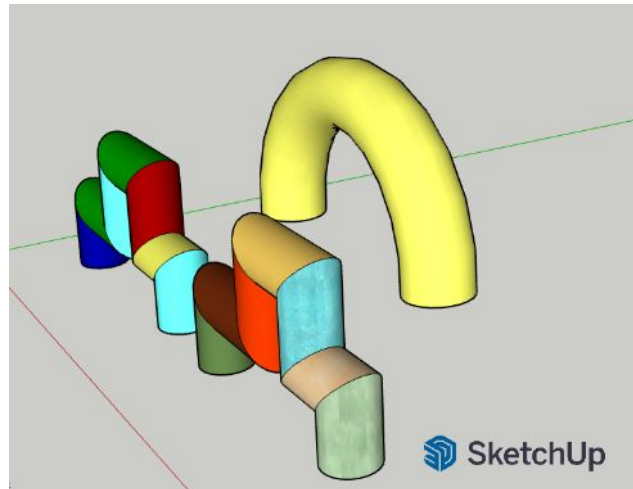

## 7. TASK 4 FOLLOW ME TOOL

