

1. Select box shape and put it on workplane.
  - Change dimensions to 40 x 100 x 60 mm.
  - Copy the shape:
    - Change it to a hole
    - Set dimensions 30 x 90 x 60 mm
    - Place it 5 mm above the workplane.
2. Centre both objects and group them.

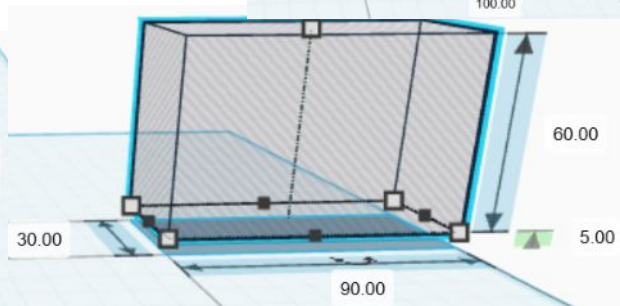
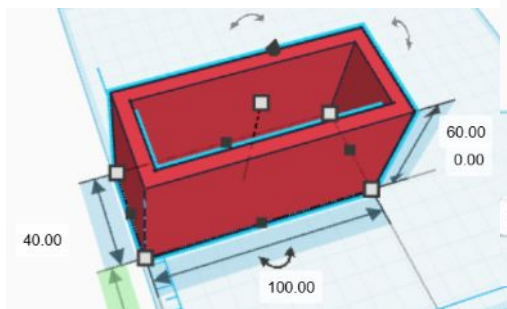
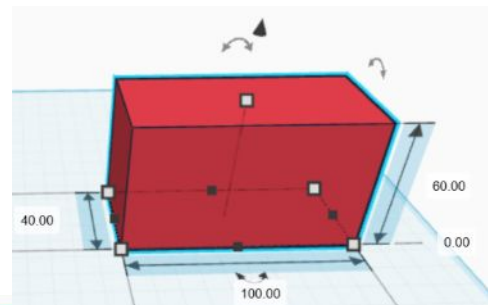

3. Select and put 4 box shapes and change

dimensions and attributes:

First one:

- 40 x 100 x 10 mm, solid

Second one:

- 29 x 89 x 30 mm, solid

Third one:

- 25 x 85 x 30 mm, hole
- Place it 5 mm above the workplane.

• Fourth one:

- 4 x 30 x 20 mm, hole

- Centre all 4 objects
- Choose bottom view and move last created shape from middle to left or right.

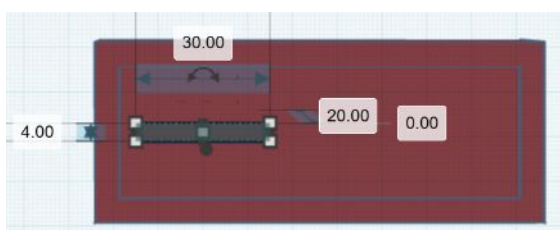
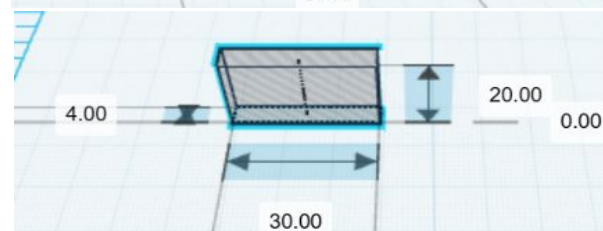
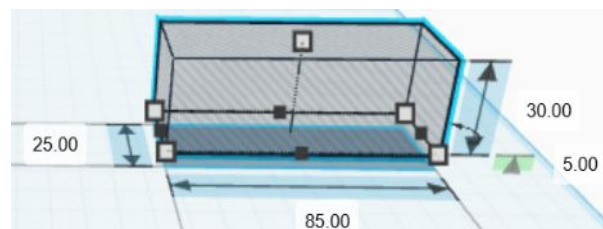
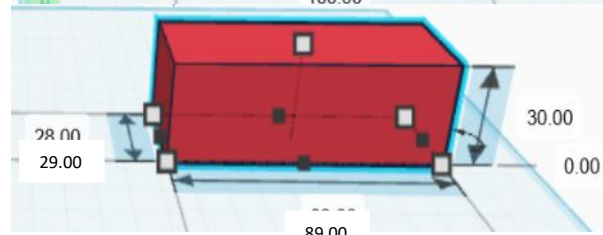
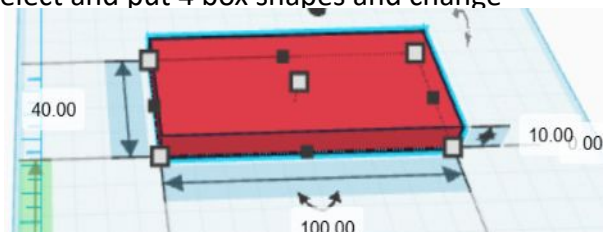

4. Group these objects, rotate the final shape and place it 40 mm above the workplane.
5. Centre 2 objects and change colours of them.

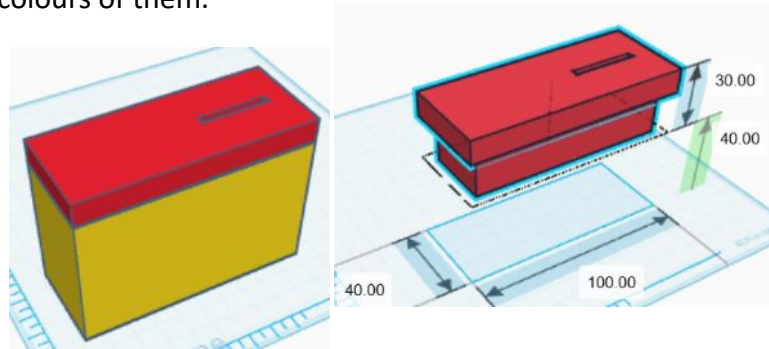

6. Select cylinder shape – hole and set dimensions 9 x 9 x 70 mm, rotate it, place it 45 mm above the workplane.
  - Copy it and centre both shapes – it will look like one object.
  - Select all shapes on workplane and centre them.
    - Click on yellow object and with holding Shift button click on hole cylinder. Group them and move it to side.
    - Group red object with second hole cylinder too.

7. Put

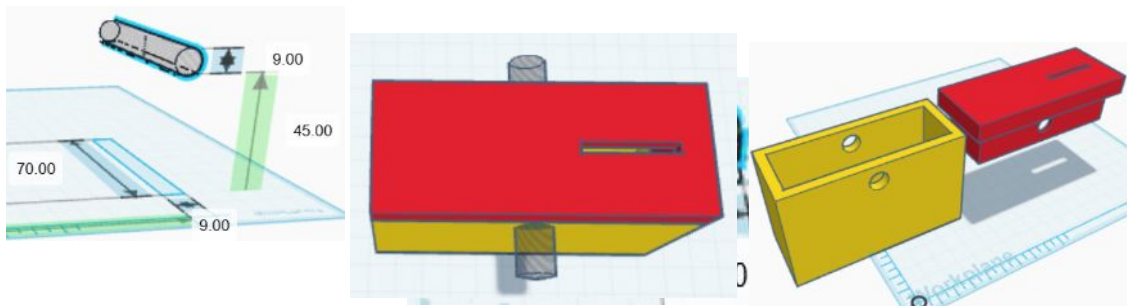

3 cylinders on workplane:

- First one – 20 x 20 x 5 mm
- Second one – 8 x 8 x 60 mm
- Third one – 5 x 5 x 20 mm
  - Rotate it
  - Place it 50 mm above WP
- Centre and group all 3 objects.

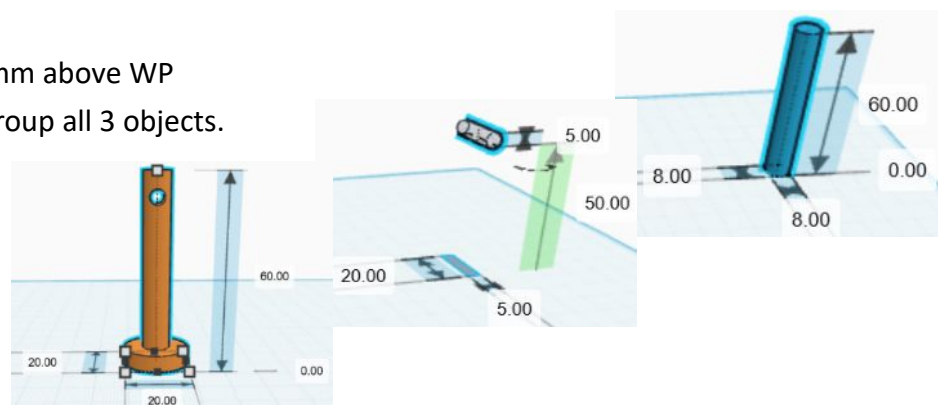

The final views:

From TOP:

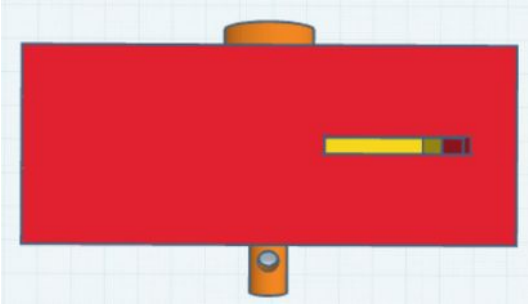

You can use some small lock to lock the money box.

FRONT side:

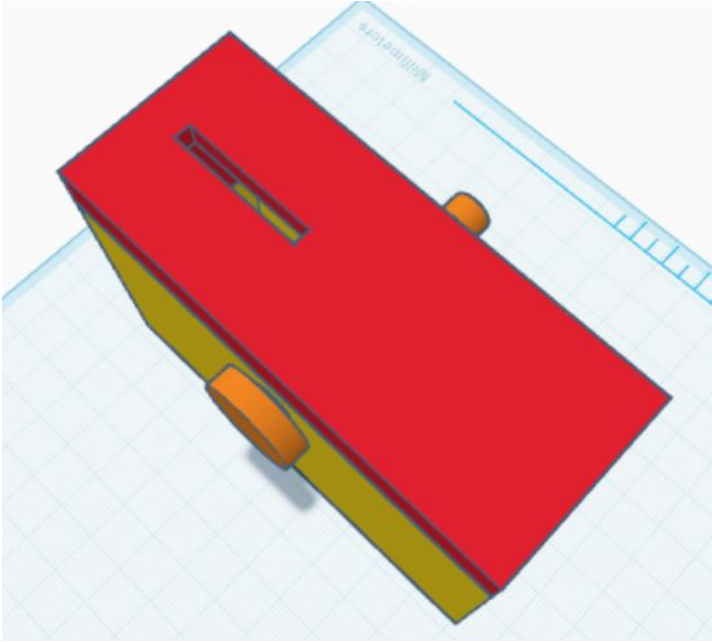
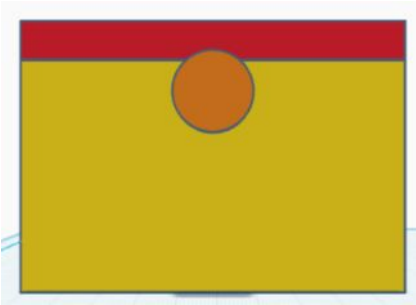

BACK side:

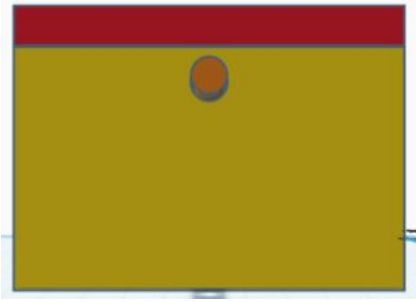

Final position for printing:

