

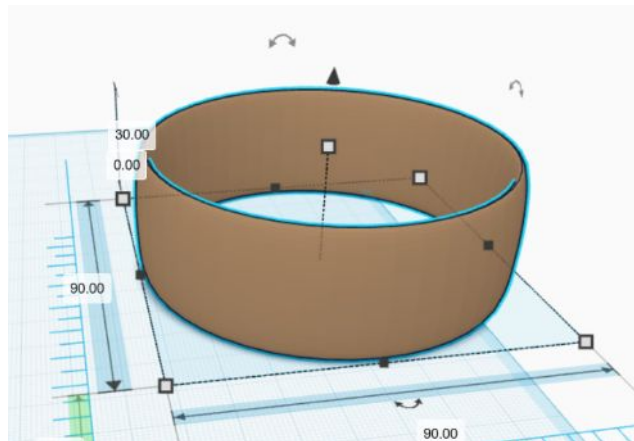

1. Create a ring 90 x 90 x 30 mm



2. Create an inscription with your name – maximum length 70 mm, width 15 mm



3. Rotate text 90 degrees.



4. Move the name above the work plane (approx. 5 mm) and increase the thickness and "pierce" the ring.

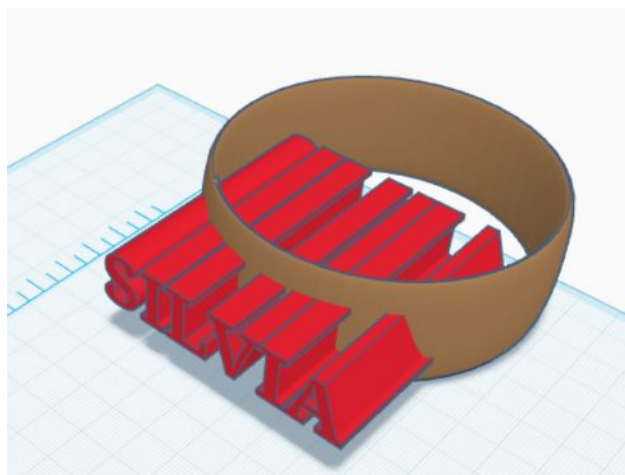

5. Align center, vertically and horizontally.



6. Text with name – change to hole.

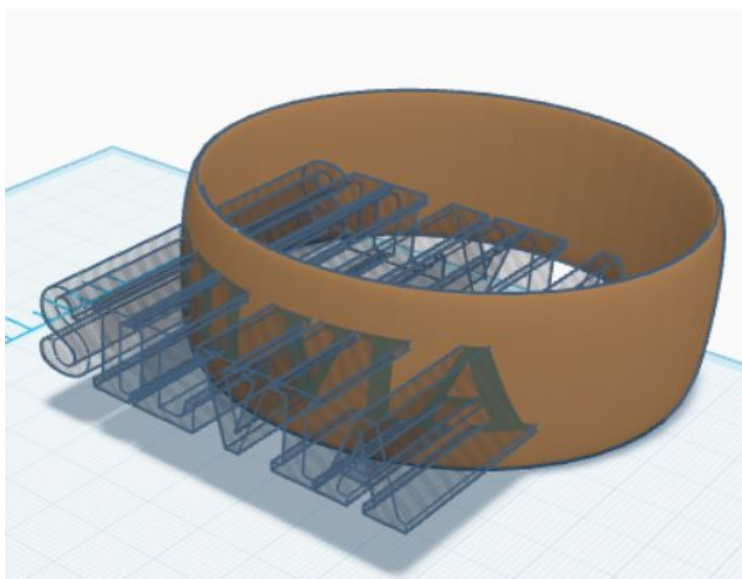

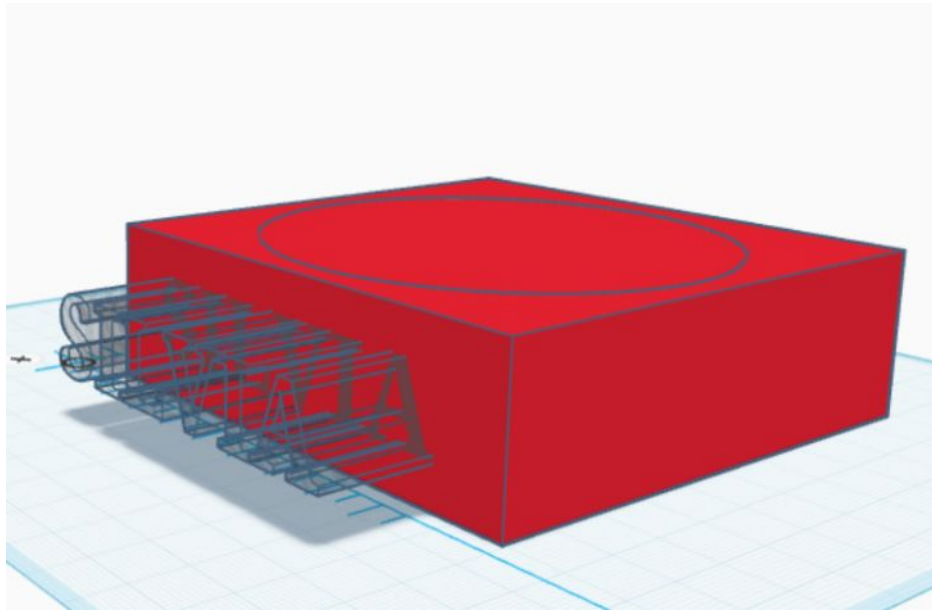

7. Make a box 30 mm high, overlap the entire ring, but let the letters stick out.

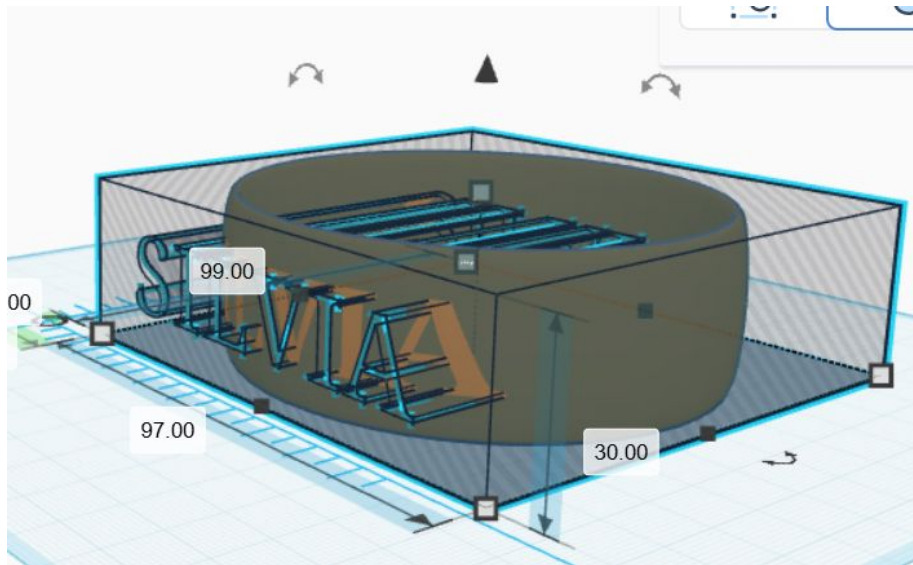

8. Group the text and box (select with the mouse and the SHIFT key), change to a hole.



9. Then hide the marked objects using the icon  .

10. Label the ring and make a duplicate of it – not a copy!! 

11. Than again we will display a box with the text  .

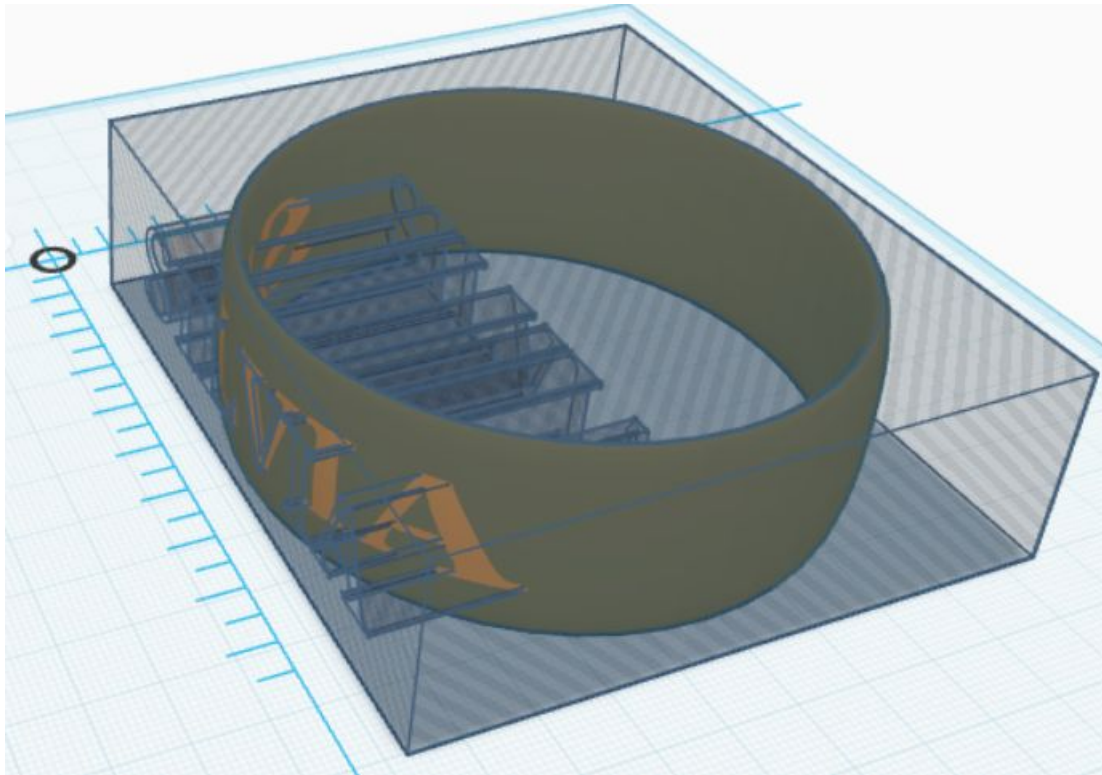

12. Use the **SHIFT** key to select the box and group them.

13. Pull the text up by about 2 mm.



14. Decoration: Make an N-side prism 10x10 mm, 90 mm long and rotate 90 degrees.

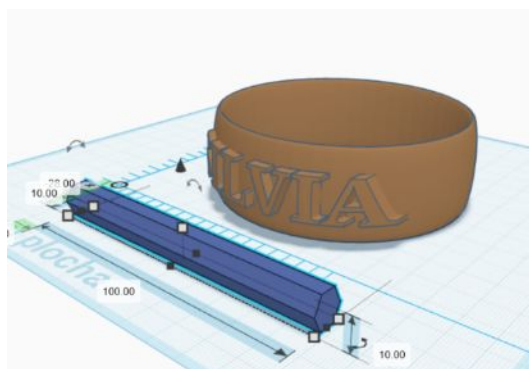

15. Lift the N side prism about 12 mm and "pierce" the ring.

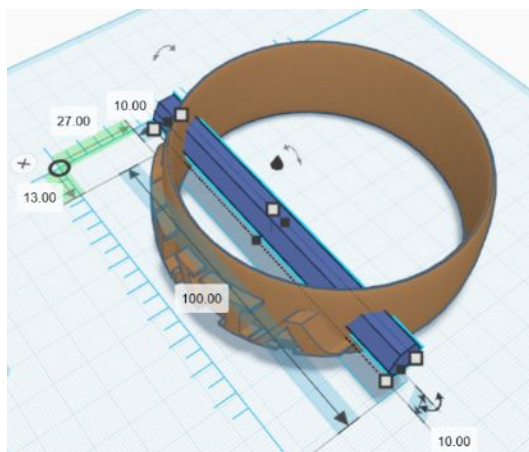

16. Copy and change to holes.

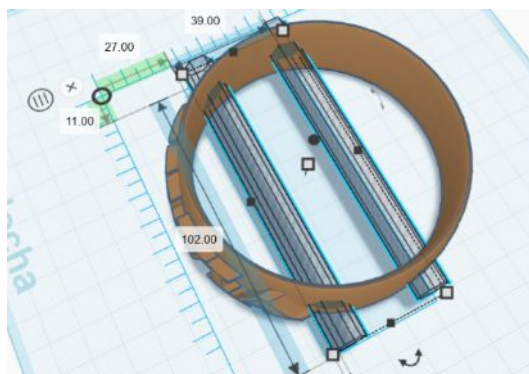

17. Group together.

